



DEDICATED TO DISCOVERY. INSPIRED BY INNOVATION.



HAWKINS
LABORATORY FUME HOODS



BENCH MOUNT FUME HOOD – VERTICAL RISING SASH

Standard Features	04
Options Overview	06
<hr/>	
EXHAUST COLLARS	
Locations / Diameters	08
Mechanical Piping Rough-ins	09
<hr/>	
CATALOG NUMBER EXPLANATION	10
INTERIOR LINER MATERIALS	11
<hr/>	
Constant Air Volume (CAV), Full By-Pass Vertical Rising Sash	12
Variable Air Volume (VAV), Restricted By-Pass Vertical Rising Sash	18
<hr/>	
BUILD YOUR FUME HOOD	20

| STANDARD FEATURES — BENCH MOUNT VERTICAL RISING SASH

HOOD TYPES

Hoods are available as:

- Constant Air Volume (CAV), Full By-Pass
- Variable Air Volume (VAV), Restricted By-Pass
- 915mm (36"), 1220mm (48"), 1525mm (60"), 1830mm(72"), 2440mm (96") wide
- Bench Mount

FINISH

- Finish is an electrostatic powder coating applied to all surfaces. Parts are baked in a controlled high temperature gas oven with infrared preheat.
- Resultant finish has a hard and smooth laboratory grade chemical resisting finish.

1 SUPERSTRUCTURE

- Fully framed, self supporting
- Exterior panels fabricated from sheet steel with baked electrostatic powder coating
- Exterior front and side panels have hidden fasteners and are removable without tools
- Exhaust collars are round in configuration and do not require rectangular-to-round transitions

2 INTERIOR ACCESS PANELS

Fully framed, self supporting

- Flush mount
- Fully framed and air tight
- No gaskets required

3 SASHES

- 6mm (7/32") laminated safety glass
- Full view type 930mm (36.5") high
- Type 316 stainless steel full length sash pull
- Maximum sash opening height 685mm (27")
- Vertical rising

4 FRONT FACE OPENING

- Aerodynamically angled top, bottom and side openings reduce turbulence and eliminate reverse flows
- Lower air foils are fabricated from 16ga type 316 stainless steel, number 4 finish

5 INTERIOR LINER MATERIALS

- Polyresin
- Stainless Steel
- PVC
- Polypropylene
- Custom materials available to fit specific requirements

6 BAFFLES

- Three section baffle design with side, upper, center and lower exhaust slots
- Baffle plates are fixed and factory set for optimum containment per ASHRAE 110-2016 Tracer Gas Testing

7 ELECTRICAL

Standard electrical fixtures comprise:

- Two 120V/20A T-slot duplex receptacles
- Vapour sealed LED lighting with light switch
- All fume hoods are factory pre-wired to a roof mounted junction box using only CSA/UL certified electrical components

APPROVALS

H.H.Hawkins Fume Hoods have been tested and certified for use in North America by Intertek Canada and designated with the cETLus mark.

Certified to the following standards: CAN/CSA-C22.2 No. 61010-1-12 + UI; U2; AI UL61010-1:2012 Ed. 3+R21 Nov2018 and UL 1805:2002

TRACER GAS TESTING

Fume Hoods are tested to the ASHRAE 110-2016 Method of Testing Performance of Laboratory Fume Hoods and exceed ANSI/AIHA Z9.5, CSA Z316.5-15 and MD15128-2013 recommendations.

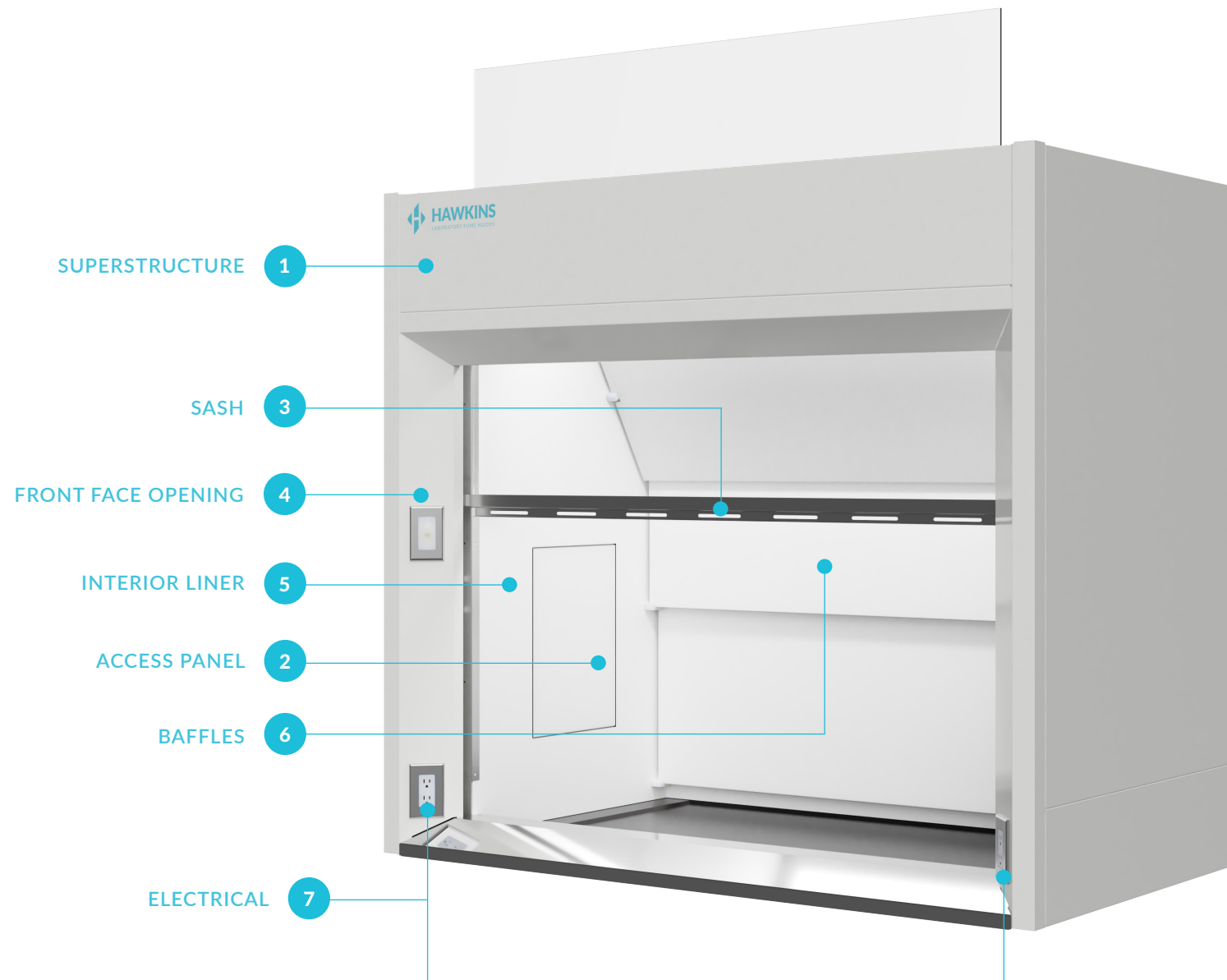

1 CEILING CLOSURE PANEL

- Designed to enclose the top of the hood to the ceiling
- Encloses both sides and front
- Front panel is removable for access to the top of the fume hood
- Fabricated from the same material as the fume hood exterior
- Colour matched to the hood exterior colour

2 MECHANICAL SERVICES FIXTURES

- Remote controlled from the front face of the fume hood
- Front loaded valves
- Factory pre-piped, conforming to applicable codes
- Colour coded handles and interior fittings
- Approved for use in North America

3 PRE-PIPING

- Factory installed terminating above or below the hood superstructure
- Burning gas: corrugated stainless steel flexible tubing with connector, conforming to applicable codes
- Water and technical gases: SPX hose with stainless steel braiding and connector termination
- Materials approved for use in North America

4 LOW AIRFLOW ALARM/MONITORS

- Factory Installed
- Built in airflow sensor continuously monitors face velocity
- LED display indicates Safe and Alarm conditions
- Pushbutton calibration and configuration, password protection

5 WORK SURFACES

- Molded dished black solid epoxy
- Type 304 or type 316 stainless steel with anti spill edges
- Custom materials to suit specific requirements

6 BASE CABINETS

- General storage non-lined. Exterior fabricated from:
 - Baked enamel steel
 - Wood veneer
 - SEFA 8M and 8W-2010 certified
- Acid/corrosives storage, polypropylene lined. Exterior fabricated from:
 - Baked enamel steel
 - Wood veneer
 - SEFA 8M and 8W-2010 certified
- Acid/corrosives storage, all polypropylene construction.
- Flammable/solvent storage. All metal double wall construction.
 - FM, UL or ULC approved
- Tubular steel table support frames

| OPTIONS OVERVIEW
VERTICAL RISING SASH



| EXHAUST COLLARS | LOCATIONS / DIAMETERS
VERTICAL RISING SASH

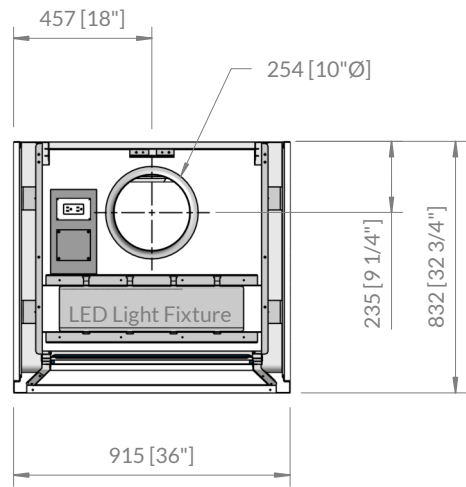

**915mm
(36") WIDE**

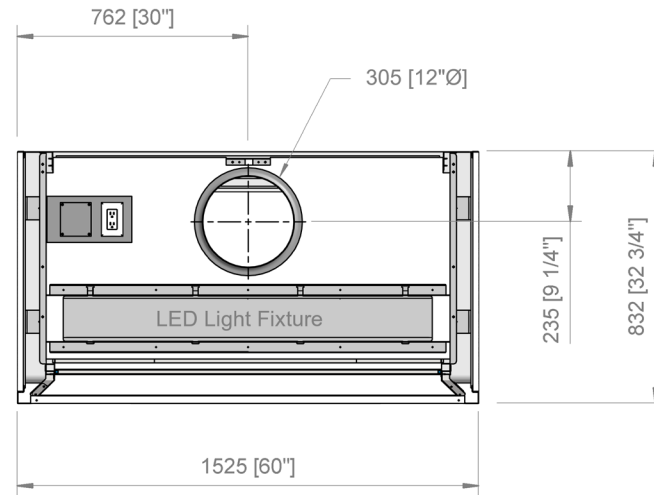

**1524mm
(60") WIDE**

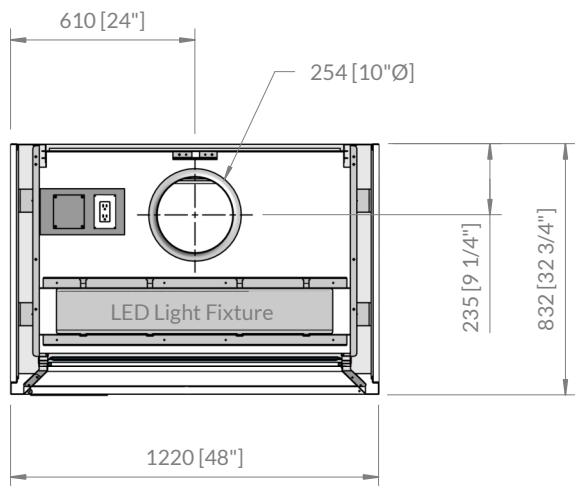

**1220mm
(48") WIDE**

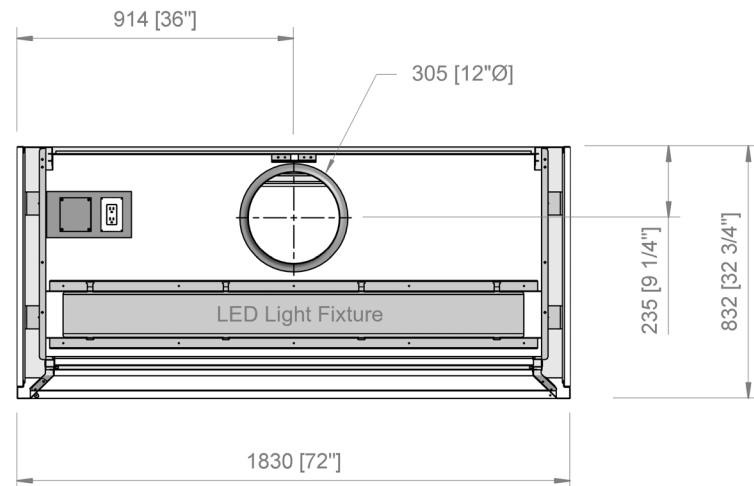

**1830mm
(72") WIDE**

| EXHAUST COLLARS | MECHANICAL PIPING ROUGH-INS
VERTICAL RISING SASH

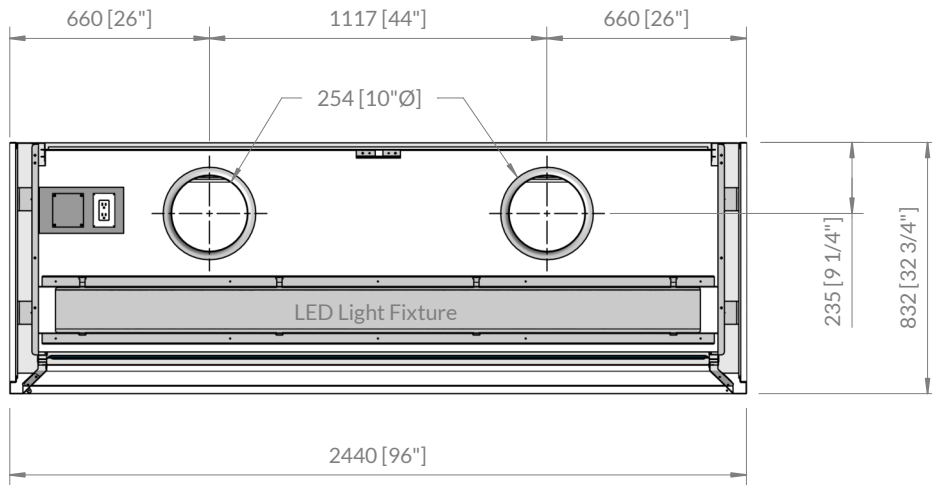

2440mm
(96") WIDE

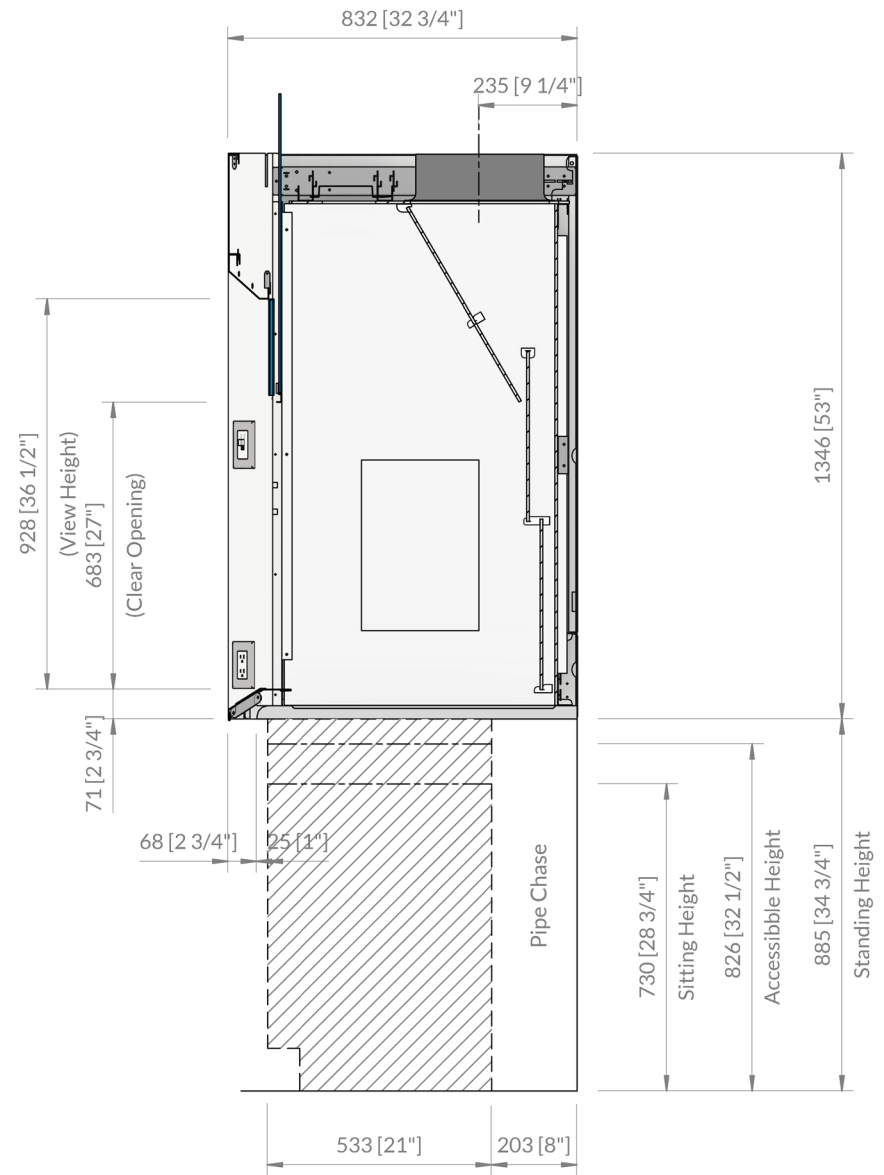

| CATALOG NUMBER EXPLANATION | INTERIOR LINER MATERIAL
VERTICAL RISING SASH

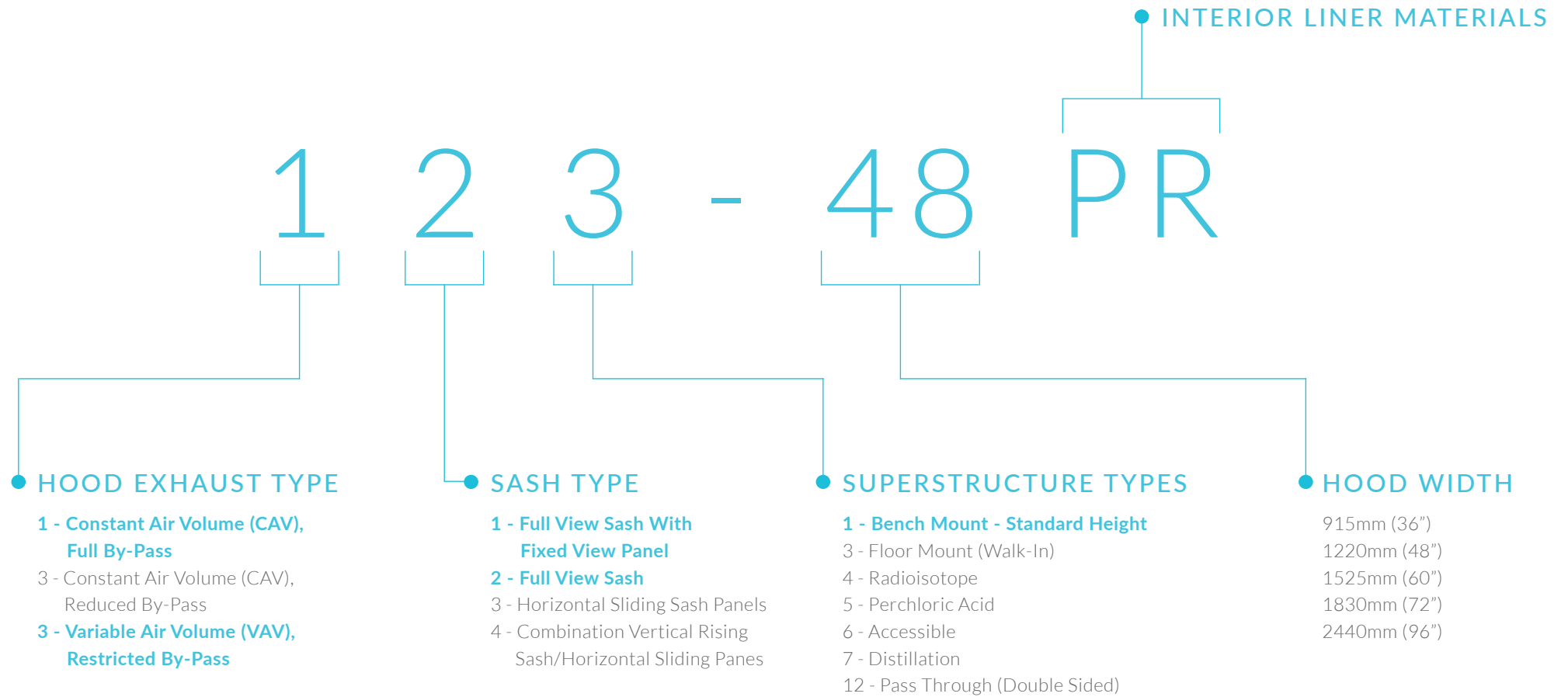

● INTERIOR LINER MATERIALS

PR Polyresin: 1/4" thick, solid fibreglass reinforced pressed thermoset resin board. Material offers superior chemical, solvent and corrosion resistance, negligible moisture absorption and a flame spread of less than 20 (UL 7231 ASTM E84-80). Flexural strength is a minimum of 19,000 PSI (D790). Material is white in colour throughout its thickness offering superior light levels. Maximum service temperature is 130 C (266 F). Exhaust collar is type 316 stainless steel.

SW Stainless Steel: Type 316 (SW6) or Type 304 (SW4) stainless steel, 16 gauge, number 4 finish, all welded seamless construction. Interior corners have a 3/4" radius and all welds are ground and polished. Liner has an integrally welded work surface with a 1/2" high anti-spill front lip. Offers excellent heat and solvent resistance and good chemical resistance to most acids. Stainless steel is not recommended for use with chemicals such as Hydrochloric Acid, Hydrofluoric Acid and Sulphuric Acid to 80% solution. Exhaust collar is Type 316 stainless steel.

ST Stainless Steel: Type 316 (ST6) or Type 304 (ST4) stainless steel, 16 gauge, number 4 finish. The sides and back of interior liner are formed in one piece with the top of the liner being stitch welded to the back and sides. Work surface is factory installed, mechanically fastened and silicone sealed. Offers excellent heat and solvent resistance and good chemical resistance to most acids. Stainless steel is not recommended for use with chemicals such as Hydrochloric Acid, Hydrofluoric Acid, and Sulphuric Acid to 80% solution. Exhaust collar is Type 316 stainless steel.

PP Polypropylene: 1/4" thick, solid, flame retardant, self extinguishing and stressed relieved polypropylene sheet. Liner is rigid and self supporting. Interior is metal-free. Material is white in colour throughout its thickness. Offers excellent corrosion resistance to a wide range of acids and solvents. Material has good impact resistance and structural integrity and has little or no water absorption. Maximum operating temperature is 82C (180F). Exhaust collar is PVC.

PV PVC: 1/4" thick, solid, flame retardant poly vinyl chloride sheet. Liner is rigid and self supporting. Interior is metal-free. Material is white in colour throughout its thickness. Offers excellent corrosion resistance to a wide range of acids but is not recommended for use with solvents. It has little or no water absorption and possesses natural flame resistant qualities. Flame resistance is rated at UL94V-O. Maximum service temperature is 60C (140F). Exhaust collar is PVC.

Technical specifications and chemical resistance chart are available upon request.

| CONSTANT AIR VOLUME (CAV), FULL BY-PASS VERTICAL RISING SASH



| CONSTANT AIR VOLUME (CAV), FULL BY-PASS VERTICAL RISING SASH

H.H.Hawkins Fume Hoods have been tested and certified for use in North America by Intertek Canada and designated with the cETLus mark. Certified to the following standards: CAN/CSA-C22.2 No. 61010-1-12 + U1; U2; AI UL61010-1:2012 Ed. 3+R21 Nov2018 and UL 1805:2002

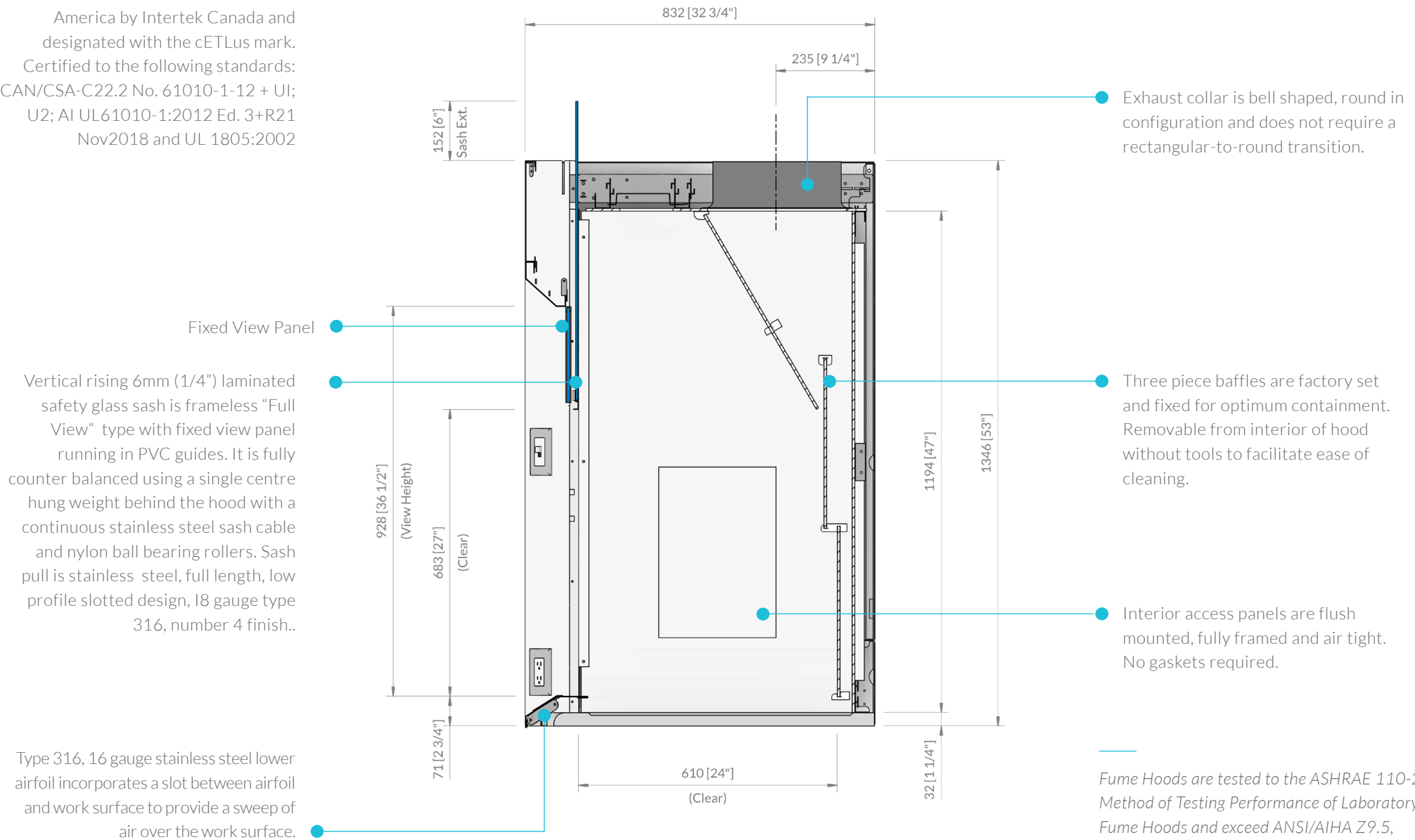

**| CONSTANT AIR VOLUME (CAV), FULL BY-PASS
VERTICAL RISING SASH**



**915mm
(36") WIDE**

Polyresin	111-36PR
Stainless Steel Type 316 (All Welded)	111-36SW6
Stainless Steel Type 304 (All Welded)	111-36SW4
Stainless Steel Type 316 (Stitch Welded)	111-36ST6
Stainless Steel Type 304 (Stitch Welded)	111-36ST4
PVC	111-36PV
Polypropylene	111-36PP



**1525mm
(60") WIDE**

Polyresin	111-60PR
Stainless Steel Type 316 (All Welded)	111-60SW6
Stainless Steel Type 304 (All Welded)	111-60SW4
Stainless Steel Type 316 (Stitch Welded)	111-60ST6
Stainless Steel Type 304 (Stitch Welded)	111-60ST4
PVC	111-60PV
Polypropylene	111-60PP



**1220mm
(48") WIDE**

Polyresin	111-48PR
Stainless Steel Type 316 (All Welded)	111-48SW6
Stainless Steel Type 304 (All Welded)	111-48SW4
Stainless Steel Type 316 (Stitch Welded)	111-48ST6
Stainless Steel Type 304 (Stitch Welded)	111-48ST4
PVC	111-48PV
Polypropylene	111-48PP



**1830mm
(72") WIDE**

Polyresin	111-72PR
Stainless Steel Type 316 (All Welded)	111-72SW6
Stainless Steel Type 304 (All Welded)	111-72SW4
Stainless Steel Type 316 (Stitch Welded)	111-72ST6
Stainless Steel Type 304 (Stitch Welded)	111-72ST4
PVC	111-72PV
Polypropylene	111-72PP

| CONSTANT AIR VOLUME (CAV), FULL BY-PASS VERTICAL RISING SASH



2440mm (96") WIDE

Polyresin	111-96PR
Stainless Steel Type 316 (All Welded)	111-96SW6
Stainless Steel Type 304 (All Welded)	111-96SW4
Stainless Steel Type 316 (Stitch Welded)	111-96ST6
Stainless Steel Type 304 (Stitch Welded)	111-96ST4
PVC	111-96PV
Polypropylene	111-96PP

- Other liner materials can be supplied to meet specific requirements.
- Base cabinets, work surfaces and plumbing fixtures are optional.
- 2745mm (108") wide and 3050mm (120") wide fume hoods also available.

AIR EXHAUST VOLUME (CFM) AND STATIC PRESSURE LOSSES (SP)

HOOD WIDTH		36"	48"	60"	72"	96"
SASH OPENING*		5.00 sq. ft.	7.30 sq. ft.	9.60 sq. ft.	11.80 sq. ft.	16.30 sq. ft.
SASH FULL OPEN (27")	80 FPM	400 @ .05	685 @ .14	770 @ .15	945 @ .22	1300 @ .18
	100 FPM	500 @ .08	730 @ .16	960 @ .22	1180 @ .29	1630 @ .24
SASH OPENING*		3.4 sq. ft.	4.9 sq. ft.	6.4 sq. ft.	7.9 sq. ft.	10.9 sq. ft.
SASH 18" OPEN	80 FPM	270 @ .02	390 @ .06	510 @ .09	630 @ .13	870 @ .06
	100 FPM	340 @ .04	490 @ .08	640 @ .13	790 @ .17	1090 @ .10

* Measured off the top of the work surface

VARIABLE AIR VOLUME (VAV), RESTRICTED BY-PASS VERTICAL RISING SASH



Variable Air Volume fume hoods are used in conjunction with an electronic control system* which will maintain a constant face velocity regardless of sash height. As the sash is raised and lowered, the VAV system will vary the exhaust volume of the hood in direct response to the sash position.

* SUPPLIED BY OTHERS.

Superstructure is fully framed and self supporting with 45° front posts. Exterior panels are 18 gauge cold rolled steel, are attached with hidden fasteners and removable without tools. Finish is an electrostatic baked powder paint for maximum scratch and chemical resistance.

All face openings are angled to reduce turbulence and maintain smooth airflow into the hood.

Standard electrical fixtures comprise two 120V/20A duplex receptacles, vapour sealed LED lighting and light switch. All fume hoods are factory pre-wired to a roof mounted junction box using only CSA/UL certified electrical components.

| VARIABLE AIR VOLUME (VAV), RESTRICTED BY-PASS VERTICAL RISING SASH

H.H.Hawkins Fume Hoods have been tested and certified for use in North America by Intertek Canada and designated with the cETLus mark. Certified to the following standards: CAN/CSA-C22.2 No. 61010-1-12 + UI; U2; AI UL61010-1:2012 Ed. 3+R21 Nov2018 and UL 1805:2002

By-pass blocker

Vertical rising 6mm (1/4") laminated safety glass sash is frameless "Full View" type with fixed view panel running in PVC guides. It is fully counter balanced using a single centre hung weight behind the hood with a continuous stainless steel sash cable and nylon ball bearing rollers. Sash pull is stainless steel, full length, low profile slotted design, 18 gauge type 316, number 4 finish..

Sash pull is slotted Type 316, 16 gauge stainless steel lower airfoil incorporates a slot between airfoil and work surface to provide a sweep of air over the work surface.

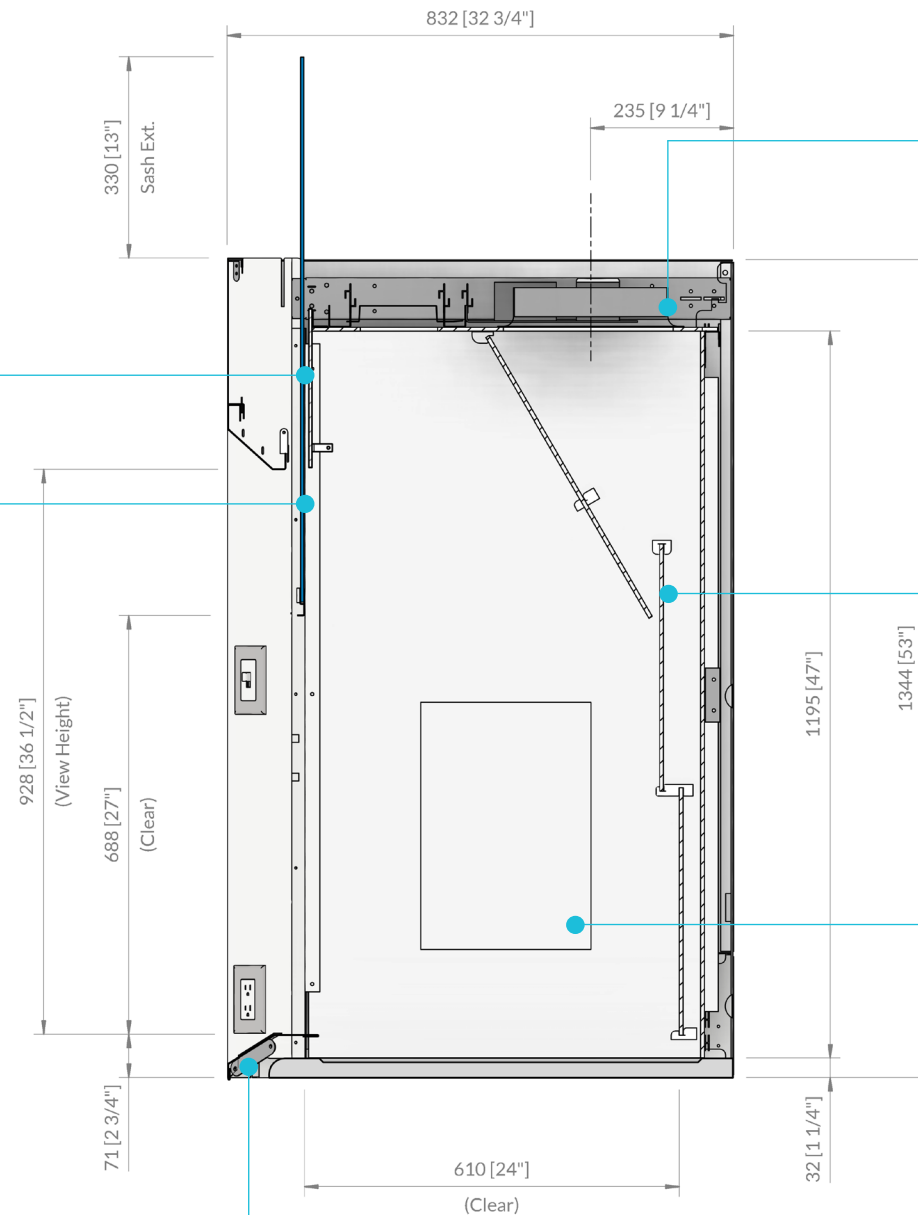

Exhaust collars are bell shaped, round in configuration and does not require a rectangular-to-round transition.

Three piece baffles are factory set and fixed for optimum containment. Removable from interior of hood without tools to facilitate ease of cleaning.

Interior access panels are flush mounted, fully framed and air tight. No gaskets required.

Fume Hoods are tested to the ASHRAE 110-2016 Method of Testing Performance of Laboratory Fume Hoods and exceed ANSI/AIHA Z9.5, CSA Z316.5-15 and MD15128-2013 recommendations.

**| VARIABLE AIR VOLUME (VAV), RESTRICTED BY-PASS
VERTICAL RISING SASH**



**915mm
(36") WIDE**

Polyresin	321-36PR
Stainless Steel Type 316 (All Welded)	321-36SW6
Stainless Steel Type 304 (All Welded)	321-36SW4
Stainless Steel Type 316 (Stitch Welded)	321-36ST6
Stainless Steel Type 304 (Stitch Welded)	321-36ST4
PVC	321-36PV
Polypropylene	321-36PP



**1525mm
(60") WIDE**

Polyresin	321-60PR
Stainless Steel Type 316 (All Welded)	321-60SW6
Stainless Steel Type 304 (All Welded)	321-60SW4
Stainless Steel Type 316 (Stitch Welded)	321-60ST6
Stainless Steel Type 304 (Stitch Welded)	321-60ST4
PVC	321-60PV
Polypropylene	321-60PP



**1220mm
(48") WIDE**

Polyresin	321-48PR
Stainless Steel Type 316 (All Welded)	321-48SW6
Stainless Steel Type 304 (All Welded)	321-48SW4
Stainless Steel Type 316 (Stitch Welded)	321-48ST6
Stainless Steel Type 304 (Stitch Welded)	321-48ST4
PVC	321-48PV
Polypropylene	321-48PP



**1830mm
(72") WIDE**

Polyresin	321-72PR
Stainless Steel Type 316 (All Welded)	321-72SW6
Stainless Steel Type 304 (All Welded)	321-72SW4
Stainless Steel Type 316 (Stitch Welded)	321-72ST6
Stainless Steel Type 304 (Stitch Welded)	321-72ST4
PVC	321-72PV
Polypropylene	321-72PP

| VARIABLE AIR VOLUME (VAV), RESTRICTED BY-PASS VERTICAL RISING SASH

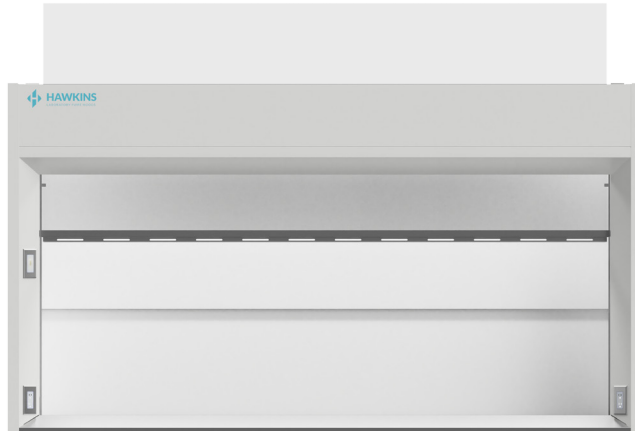

2440mm (96") WIDE

Polyresin311-96PR

Stainless Steel Type 316 (All Welded) 321-96SW6

Stainless Steel Type 304 (All Welded) 321-96SW4

Stainless Steel Type 316 (Stitch Welded) 321-96ST6

Stainless Steel Type 304 (Stitch Welded) 321-96ST4

PVC 321-96PV

Polypropylene 321-96PP

- Other liner materials can be supplied to meet specific requirements.
- Base cabinets, work surfaces and plumbing fixtures are optional.
- 2745mm (108") wide and 3050mm (120") wide fume hoods also available

AIR EXHAUST VOLUME (CFM) AND STATIC PRESSURE LOSSES (SP)

HOOD WIDTH		36"	48"	60"	72"	96"
SASH OPENING*		5.00 sq. ft.	7.30 sq. ft.	9.60 sq. ft.	11.80 sq. ft.	16.30 sq. ft.
SASH FULL OPEN (27")	80 FPM	400 @ .05	685 @ .14	770 @ .15	945 @ .22	1300 @ .18
	100 FPM	500 @ .08	730 @ .16	960 @ .22	1180 @ .29	1630 @ .24
SASH OPENING*		3.4 sq. ft.	4.9 sq. ft.	6.4 sq. ft.	7.9 sq. ft.	10.9 sq. ft.
SASH 18" OPEN	80 FPM	270 @ .02	390 @ .06	510 @ .15	630 @ .13	870 @ .06
	100 FPM	340 @ .04	490 @ .08	640 @ .13	790 @ .17	1090 @ .10

* Measured off the top of the work surface

VERTICAL RISING SASH BUILD YOUR FUME HOOD



PROJECT _____

WIDTH _____

QUANTITY _____

1 FUME HOOD AIRFLOW

- Constant Air Volume (CAV)
- Variable Air Volume (VAV)

2 FUME HOOD TYPE

- General Chemistry

3 LINER MATERIAL

- Polyresin (PR)
- S/S All Welded T316 (SW6)
- S/S Stitch Welded T316 (ST6)
- S/S All Welded T304 (SW4)
- S/S Stitch Welded T304 (ST4)
- Other

Refer to page 11 of the catalog
for liner material description.

- Ceiling Closure Panels
- Blower Switch (Wiring NIC)
- Sash Stop at 18"

Mechanical Services

Cup Sink

- 6"x3" Polyethylene
- 6"x3" T316 Stainless Steel

Base Cabinets Left Side

- Acid Storage
- Flammable Storage
- General Storage
- Table Frame

Additional Options



Pre-piping

- Above the hood
- Below the hood

Low Air Flow Alarm

- AFA500 (CAV Only)
- AFA1000 (CAV Only)
- AFA4000 (CAV Only)

Mechanical Services

Cup Sink

- 6"x3" Polyethylene
- 6"x3" T316 Stainless Steel

Work Surface

- Epoxy
- Stainless Steel, T316

Base Cabinets Right Side

- Acid Storage
- Flammable Storage
- General Storage
- Table Frame

Additional Options

YOUR RESEARCH DRIVES OUR INNOVATION.





Unit 107 - 19298 21st Ave Surrey, BC V3Z 3M3

1-800-661-4454